

PGM-5

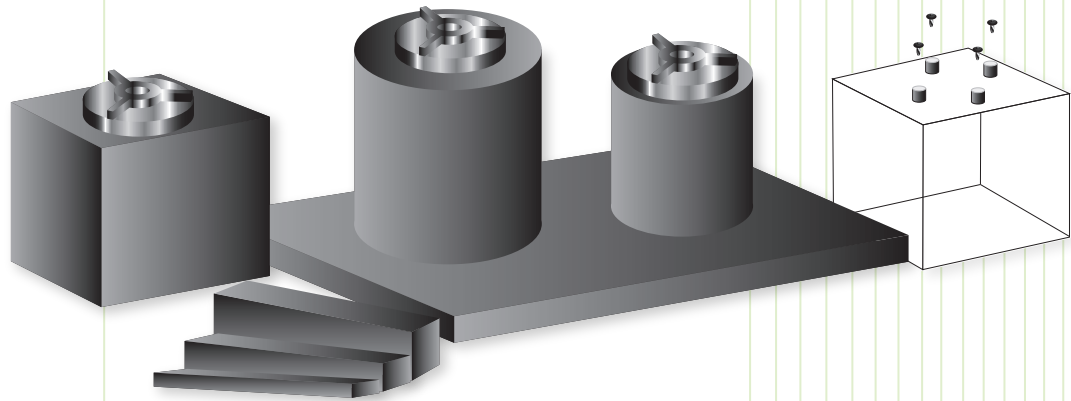

GENERAL

Isomolded, fine micro grain, high strength, isotropic graphite. Maximum insert atmosphere service temperature 5,000°F (2,760°C).

APPLICATION

Micro-Grain EDM Graphite which allows for exceptional surface finishes associated with lower electrode wear rates and best possible metal removal rates.

PROPERTIES

Bulk Density	1.86 gm/cm ³
Average Grain Size	.0002 in
Specific Resistance	.00050 ohm in
Flexural Strength	11,000 PSI
Compressive Strength	24,200 PSI
Hardness:	72 Shore

FULL STOCKING DISTRIBUTOR OF EDM SUPPLIES, MOLD COMPONENTS & POLISHING SUPPLIES.

11650 96TH AVE. N.
MINNEAPOLIS, MN 55369

PN: 763-424-1189 TF PN: 800-888-9080
FX: 763-424-9460 TF FX: 800-299-9954

WWW.EDMSALESINC.COM

PGM-5