

E-20

EDM

Sales & Supplies, Inc

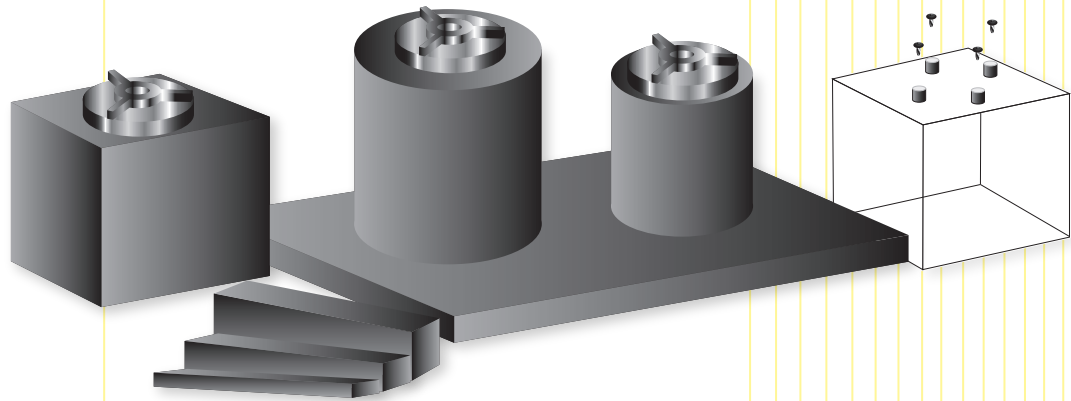

GENERAL

Isomolded, fine grain, high strength, high density, isotropic graphite, maximum inert service temperature 5,000 F (2,760 C)

APPLICATION

High quality EDM graphite. A good universal material which yields both good metal removal rates and wear characteristics producing an excellent surface finish of 5.5 to 4.5 Ra μ m.

PROPERTIES

Bulk Density	1.82 gm/cm ³
Average Grain Size	.0005 in
Specific Resistance	.00049 ohm in
Flexural Strength	8,400 PSI
Compressive Strength	18,400 PSI
Hardness	70 Shore

FULL STOCKING DISTRIBUTOR OF EDM SUPPLIES, MOLD COMPONENTS & POLISHING SUPPLIES.

11650 96TH AVE. N.
MINNEAPOLIS, MN 55369

PN: 763-424-1189 TF PN: 800-888-9080
FX: 763-424-9460 TF FX: 800-299-9954

WWW.EDMSALESINC.COM

E-20