

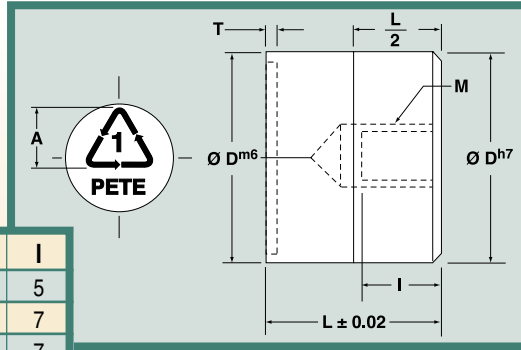

Recycle Inserts SPI Standards

NEW



D	L	A	M	T	I
8	10	5	M4	0,2	5
10	12	6	M5	0,3	7
12	14	7	M5	0,3	7
16	14	10	M6	0,3	7
20	16	12	M6	0,3	8

- Standards with threaded holes
- Based upon US SPI standards
- Material: 420 Stainless; 1.4021; 46Hrc+/- 2
- Maximum working temperature: 300F

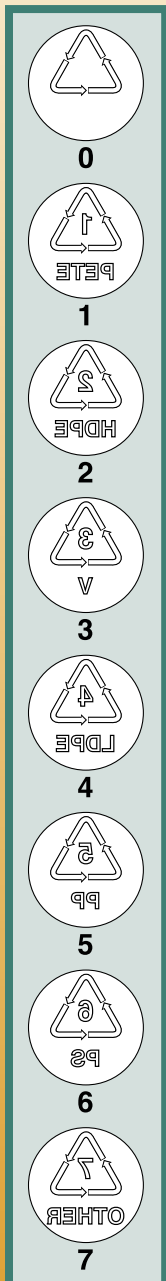

Catalog Number	D	Recycling Number	Abbreviation	Polymer Name
MA-08-01	8	1	PETE	Polyethelene, Terephthalate
MA-08-02	8	2	HDPE	High Density Polyethelene
MA-08-03	8	3	PVC(or V)	Polyvinyl Chloride
MA-08-04	8	4	LDPE	Low-Density Polyethelene
MA-08-05	8	5	PP	Polypropelene
MA-08-06	8	6	PS	Polystyrene
MA-08-07	8	7	"OTHER"	All other resins
MA-08-00	8	N/A	N/A	Blank
MA-10-01	10	1	PETE	Polyethelene, Terephthalate
MA-10-02	10	2	HDPE	High Density Polyethelene
MA-10-03	10	3	PVC(or V)	Polyvinyl Chloride
MA-10-04	10	4	LDPE	Low-Density Polyethelene
MA-10-05	10	5	PP	Polypropelene
MA-10-06	10	6	PS	Polystyrene
MA-10-07	10	7	"OTHER"	All other resins
MA-10-00	10	N/A	N/A	Blank
MA-12-01	12	1	PETE	"Polyethelene, Terephthalate"
MA-12-02	12	2	HDPE	High Density Polyethelene
MA-12-03	12	3	PVC(or V)	Polyvinyl Chloride
MA-12-04	12	4	LDPE	Low-Density Polyethelene
MA-12-05	12	5	PP	Polypropelene
MA-12-06	12	6	PS	Polystyrene
MA-12-07	12	7	"OTHER"	All other resins
MA-12-00	12	N/A	N/A	Blank
MA-16-01	16	1	PETE	Polyethelene, Terephthalate
MA-16-02	16	2	HDPE	High Density Polyethelene
MA-16-03	16	3	PVC(or V)	Polyvinyl Chloride
MA-16-04	16	4	LDPE	Low-Density Polyethelene
MA-16-05	16	5	PP	Polypropelene
MA-16-06	16	6	PS	Polystyrene
MA-16-07	16	7	"OTHER"	All other resins
MA-16-00	16	N/A	N/A	Blank
MA-20-01	20	1	PETE	Polyethelene, Terephthalate
MA-20-02	20	2	HDPE	High Density Polyethelene
MA-20-03	20	3	PVC(or V)	Polyvinyl Chloride
MA-20-04	20	4	LDPE	Low-Density Polyethelene
MA-20-05	20	5	PP	Polypropelene
MA-20-06	20	6	PS	Polystyrene
MA-20-07	20	7	"OTHER"	All other resins
MA-20-00	20	N/A	N/A	Blank