

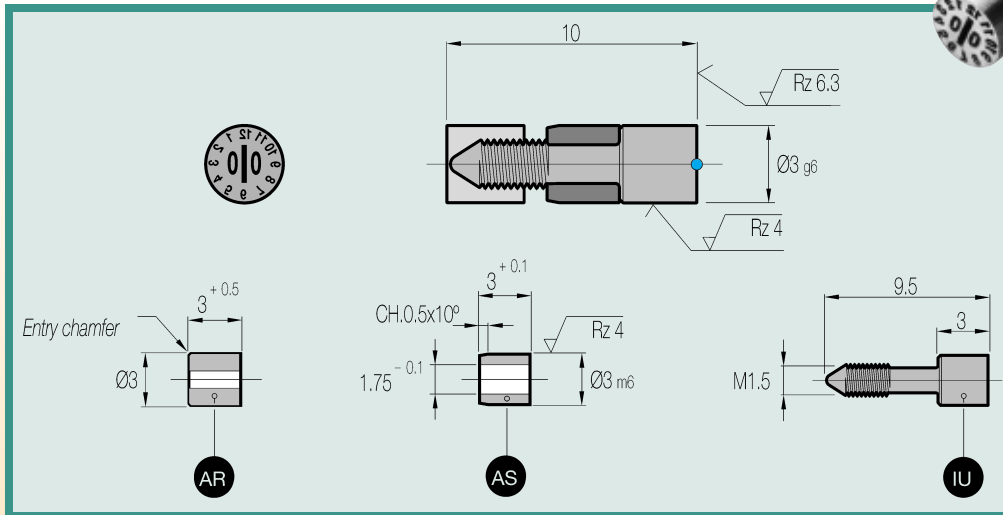

Micro Date Stamp

Ø 3mm

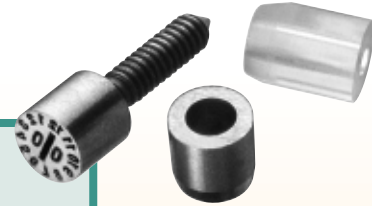

Ideal for limited spaces due to their small size.

- Material is INOX.1.4034 – 48-54HRC
- Maximum working temperature is 150°C

Micro Date Stamp Assemblies (MDA) are supplied complete with (IU) Unit Insert, (AS) Support Unit, (AR) Retention Ring and (UM) Mounting Jig

Blank	12 Months/ Year	12 Months/ No Year	Blank	12 Months/ Year	12 Months/ No Year
MDA031000	1MDA031012-__	MDA03101SF	IU031000	1IU031095-__	IU0310SF

(1) When ordering add the year required to the part number (MDA031012-06)

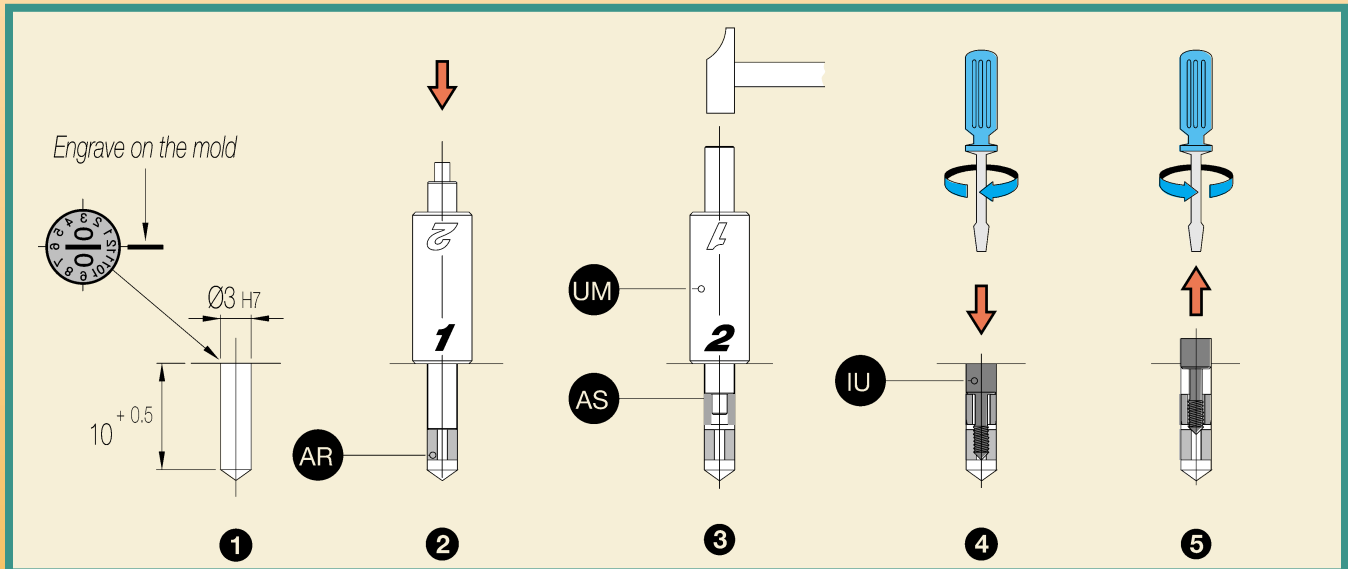

- 1 - Machine pocket and mark reference point or line on cavity.
- 2 - Insert Retention Ring (AR) with Mounting Jig (UM) position 1.
- 3 - Drive fit Support Ring (AS) with Mounting Jig (UM) position 2.
- 4 - Screw in the Unit Insert (IU).
- 5 - Unscrew the Unit Insert (IU) to change the year.

CAD files and flash demo at:
CUMSA
www.cumsa.com