

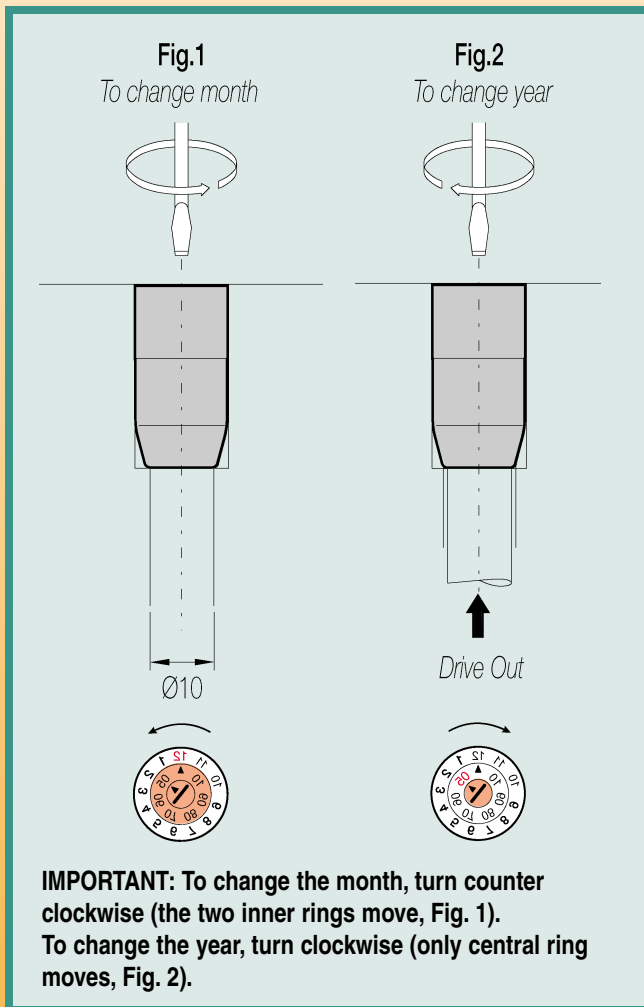

Double Date Stamp

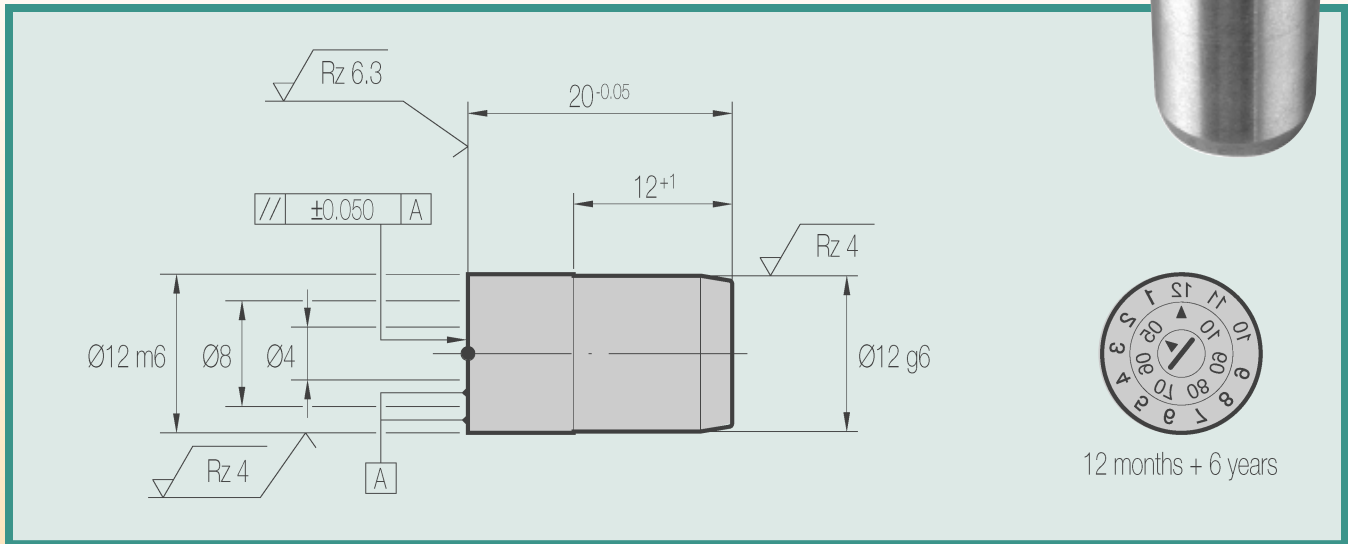

Catalog Number

FD-120812- _ _ _

* To order, fill in the start or base year after the dash.

- Allows two different impressions on the plastic part without the use of two date stamps, reducing costs and space required.
- The same height is maintained between all the rings.
- Material INOX 1.4034 – Hardened 48-54 HRC
- Maximum working temperature 100°C
- This is a Cumsa patented system.

Blank Double Date Stamp

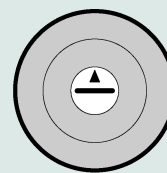

Catalog Number

FD-120800

CAD files and flash demo at:

CUMSA
www.cumsa.com