

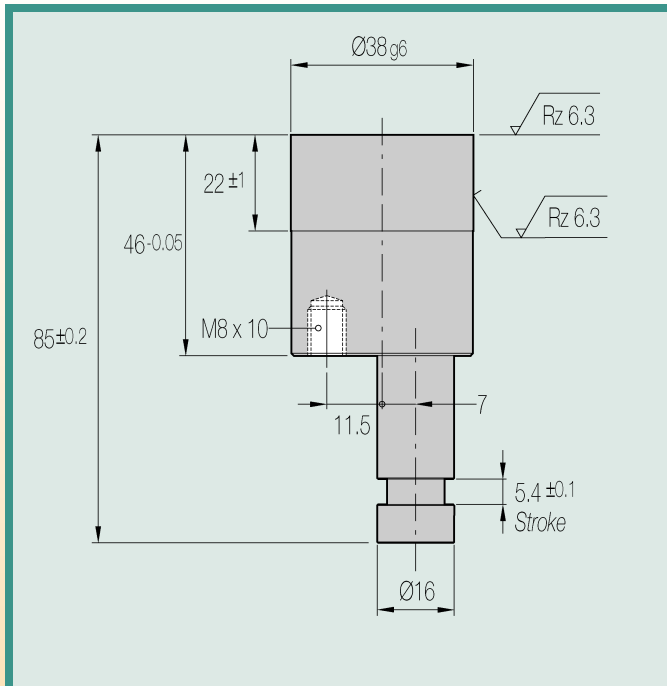

Sequential Marker

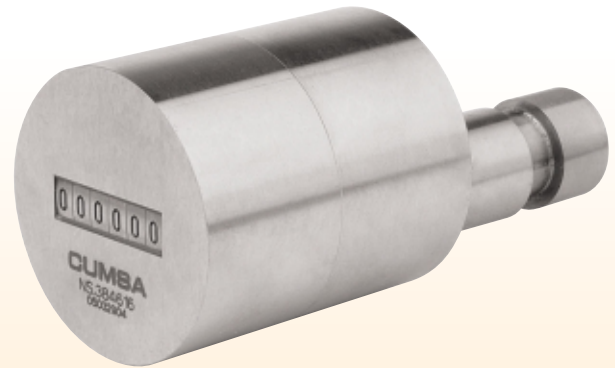

- Each injected part is sequentially marked with its own part number, through the action of the ejector plate movement.
- Material INOX 1.4034 – Hardened 48-54 HRC
- This is a Cumsa patented system.
- It is recommended that a safety stopper be used to limit the ejector plate stroke. See below.

Catalog Number

NS-384616

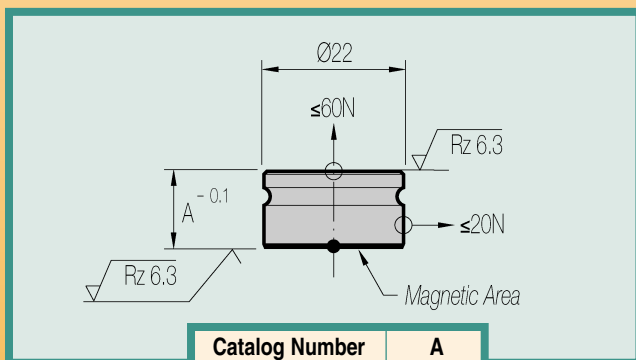
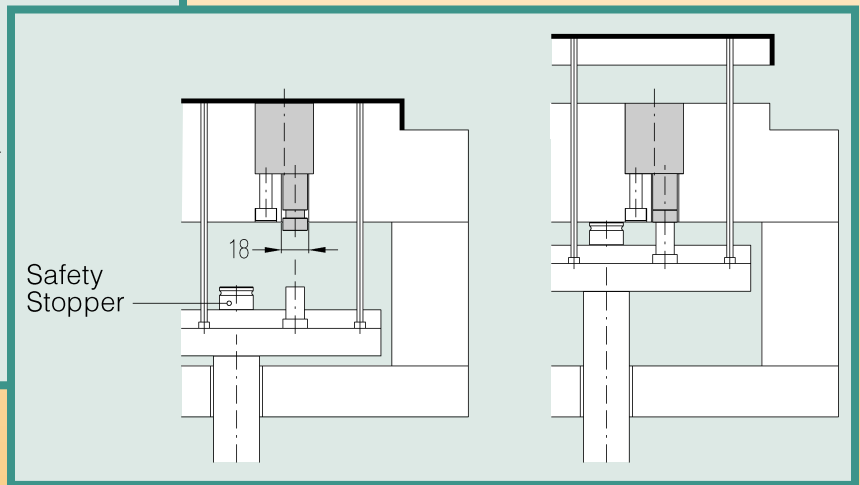
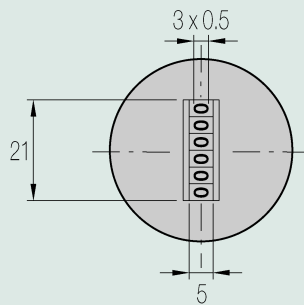

Safety Stopper

- Magnetic safety stop that can be easily installed and removed.
- Material 1.7242 – 55-60 HRC
- Maximum working temperature 130°C



Catalog Number

A

TM-102214	10.0
TM-122214	12.5
TM-152214	15.0
TM-202214	20.0

CAD files and flash demo at:

CUMSA
www.cumsa.com