

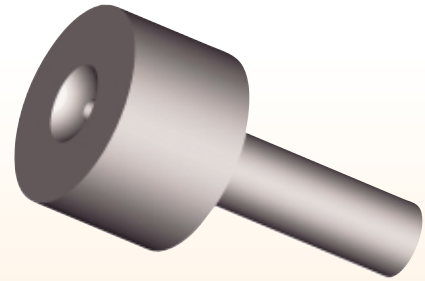

# Sprue Bushings

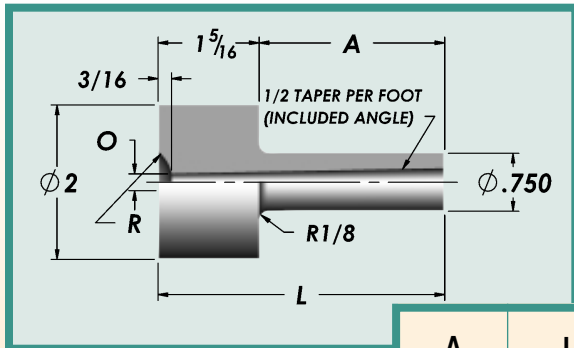

## UV-Series

A	L	O=5/32	O=7/32	O=9/32
		R=1/2	R=1/2	R=1/2
29/32	2-7/32	UV239512	UV239712	UV239912
1-13/32	2-23/32	UV255512	UV255712	UV255912
1-29/32	3-7/32	UV339512	UV339712	UV339912
2-13/32	3-23/32	UV355512	UV355712	UV355912
2-29/32	4-7/32	UV439512	UV439712	UV439912

# Sprue Reamers

MACHINE REAMER (ROUGHING)

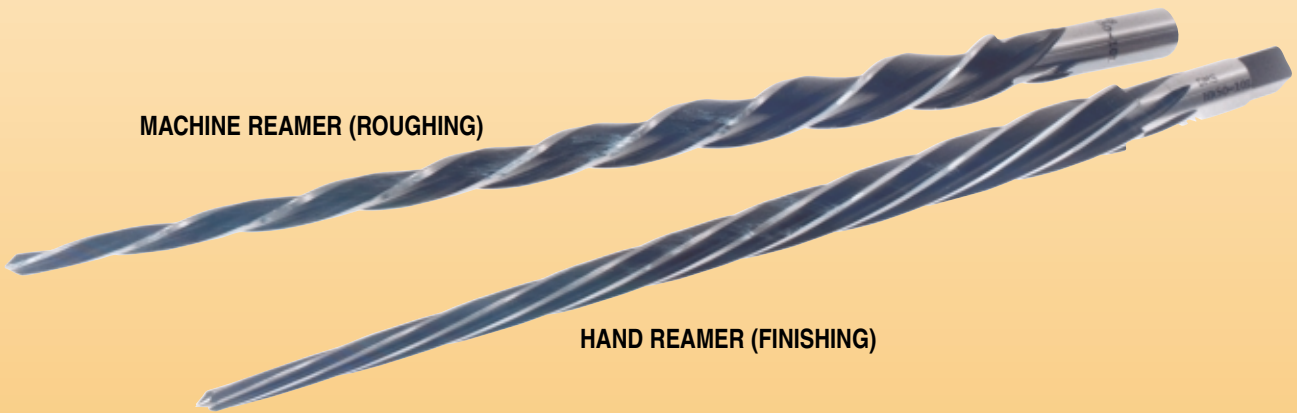

HAND REAMER (FINISHING)

HAND REAMERS						
Catalog Number	Flutes	Taper per foot	Diameter Small End	Diameter Large End	Shank Diameter	Flute Length
HR-50-06S	4	1/2	7/64	3/8	3/8	6"
HR-50-10L	6	1/2	13/64	5/8	5/8	10-1/2"

MACHINE REAMERS						
Catalog Number	Flutes	Taper per foot	Diameter Small End	Diameter Large End	Shank Diameter	Flute Length
MR-50-06S	3	1/2	7/64	3/8	3/8	6"
MR-50-10L	3	1/2	13/64	5/8	5/8	10-1/2"