

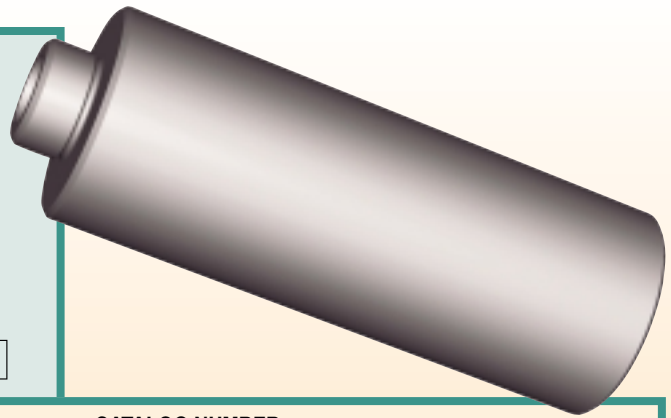

Guided Ejection Support Pillars

Metric

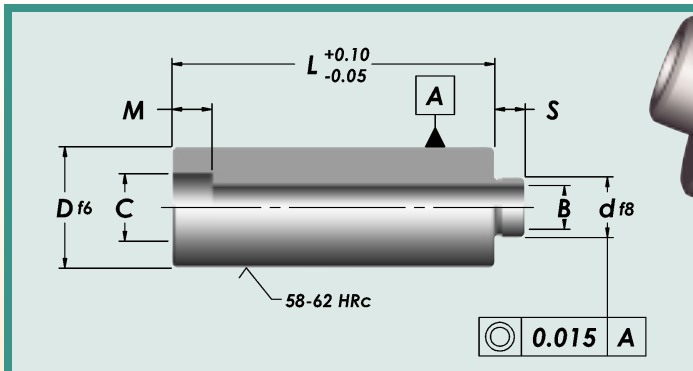

D	C	M	B	d	S	CATALOG NUMBER								
						L=36	L=46	L=56	L=76	L=96	L=116	L=136	L=156	
24	15	9	9	14	7	SSP-24x36	SSP-24x46	SSP-24x56	SSP-24x76	SSP-24x96				
36	18	11	11	18	9		SSP-36x46	SSP-36x56	SSP-36x76	SSP-36x96	SSP-36x116	SSP-36x136		
48	20	13	13	20	10				SSP-48x76	SSP-48x96	SSP-48x116	SSP-48x136	SSP-48x156	

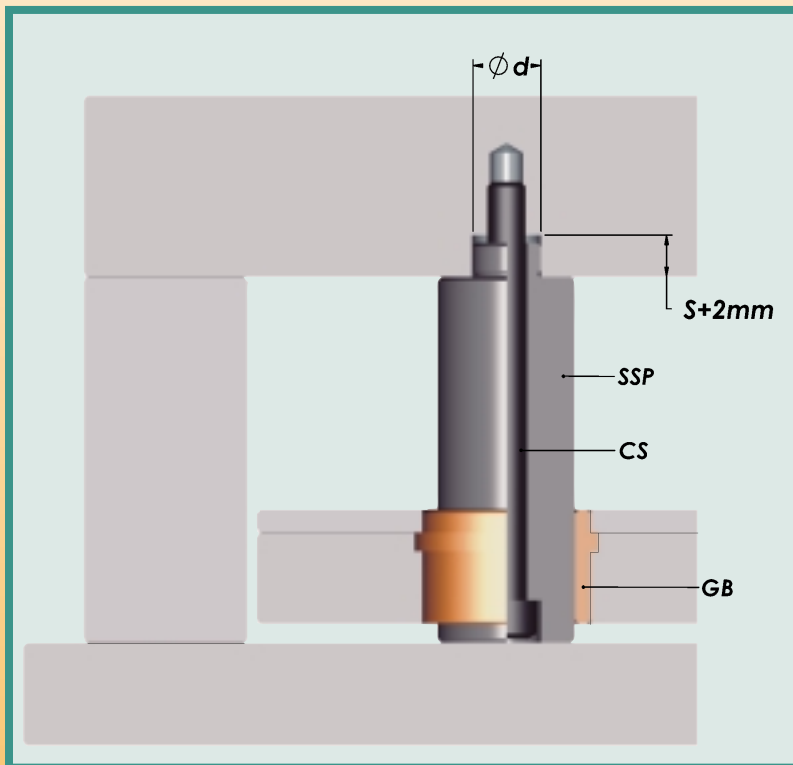

- All 'SSP' guided ejection support pillars are case hardened to the same standards as DMS leader pins.
- Assembly is suggested with metric capscrews (not supplied).
- SSP24 series use M8 capscrew.
- SSP36 series use M10 capscrew.
- SSP48 series use M12 capscrew.

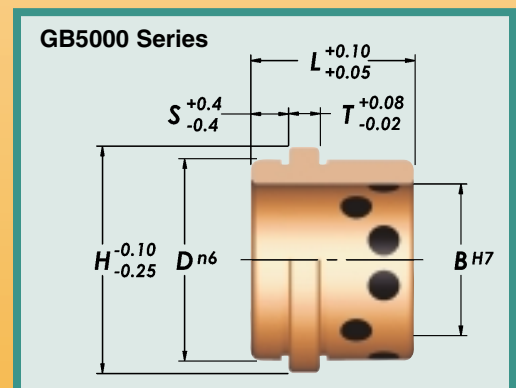
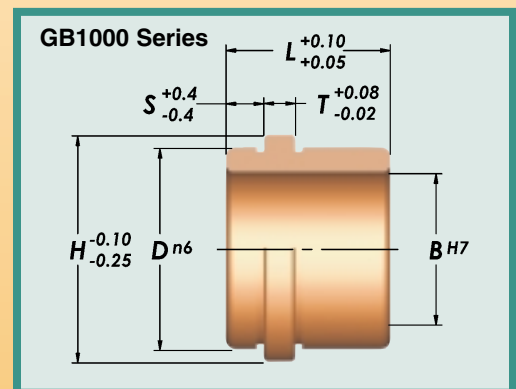

B	D	H	S	T	L	Part Number	
24	32	36	6	5	26	GB1000	GB5000
36	44	48	6	5	30	GB1001	GB5001
48	58	62	10	6	40	GB1002	GB5002