

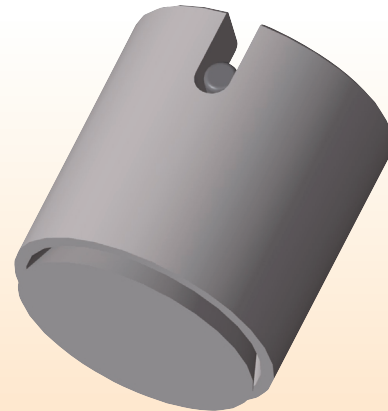

Air Ejectors Standard

- Designed to assist in breaking the vacuum created when molding deep molded parts or thin walled parts such as flower pots, garbage cans and containers.
- The valve and body are made from hardened Stainless Steel 45-50 HRC.



INCH

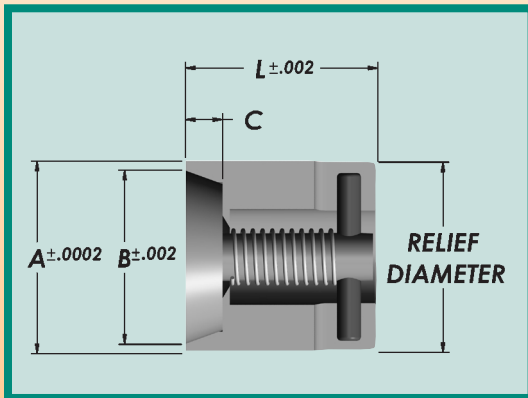

Catalog Number	Nominal I.D.	A	B	L	C
AE025	1/4	.2505	.225	.252	.05
AE037	3/8	.3755	.325	.377	.07
AE050	1/2	.5005	.437	.502	.10
AE062	5/8	.6255	.562	.627	.13
AE075	3/4	.7505	.656	.752	.15
AE100	1"	1.0005	.875	1.002	.20
AE150	1-1/2	1.5005	1.312	1.502	.30

METRIC

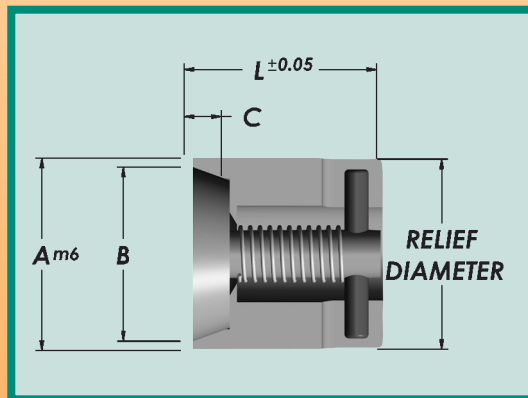

Catalog Number	Nominal I.D.	A	B	L	C
AE08MM	8	.3149	6.5	12	1,5
AE10MM	10	.3937	8	12	2,0
AE12MM	12	.4724	10	12	2,5
AE16MM	16	.6299	13	20	3
AE20MM	20	.7874	17	20	3,5